

Remote-Controlled Positioning System PS 400

(230 V, 50/60 Hz) 1023414
 (115 V, 50/60 Hz) 1023791

Instruction Manual

03/23 TL

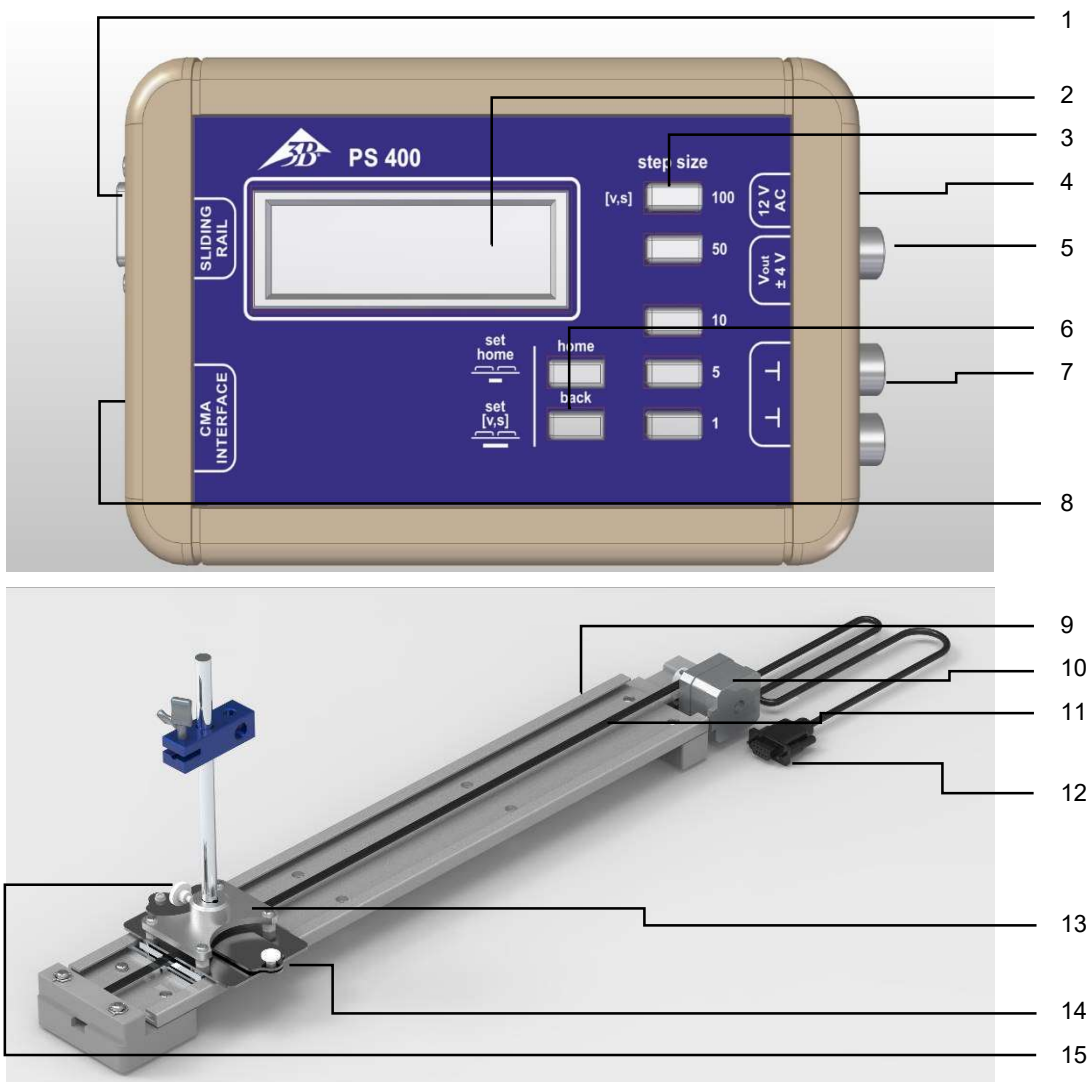

- | | |
|--|--|
| <ul style="list-style-type: none"> 1 Connection socket for sliding rail (12) 2 Display 3 Keys <i>step size</i> for moving steps (mm) 4 Connection for AC power supply 5 Voltage output V_{out} 6 Function keys 7 2 x ground socket | <ul style="list-style-type: none"> 8 Interface for CMA-sensors 9 Sliding rail 10 Step motor 11 Transport belt 12 Connection cable for control unit (1) 13 Sled, mounting assembly 14 Screw for clutch force 15 Lock for mounting assembly (13) |
|--|--|

1. Safety instructions

Plug-in power supply 230 V (1001014)/ 115 V (1009545):

- Operation only with the mains voltage according to the imprint.
- Do not use the device if there is visible damage to the housing, plug or cable.

PS 400:

- Connect or disconnect the control unit to the sliding rail inly without connected power supply.
- Adjust the clutch force with the screw (14) (allows the belt to slide in case of collision at the end of the track or on sensitive components, see 5.).
- The sensor cable 1021514 is needed for the CMA interface (8).
- Do not apply voltage to the voltage output V_{out} (5).

2. Description

The Remote-Controlled Positioning System PS 400 enables fast and exactly reproducible positioning of components in experiments.

Fixed and programmable positioning steps with assigned and programmable moving velocities offer a high degree of flexibility with particularly simple operation.

Experiments can be performed quickly and without disturbing influences of the person performing the experiment.

The CMA interface (8) enables recording the position of the sled on the sliding rail via computer or VinciLab (1021477). The position of the sled can also be determined via the voltage output (5). Measurement data from other sensors can thus be recorded as a function of the sled's position and quickly evaluated.

3. Scope of delivery

- 1 Sliding rail
- 1 Control unit PS400
- 1 Stand rod: $\varnothing = 10$ mm, length: 200 mm
- 1 Tripod muff
- 1 Plug-in power supply 230 V (1001014) or 115 V (1009545)

4. Technical data

Sliding rail:

Weight:	2 kg
Moving distance:	405 mm
Stand rod mount:	$\varnothing = 10$ mm
Dimensions:	580x120x50 mm ³

Control Unit PS400:

The control unit has fixed programmed keys *step size* (3). Pressing a button once moves the sled the distance s at the velocity v :

"1"	$s = 1$ mm	$v = 1$ mm/s
"5"	$s = 5$ mm	$v = 5$ mm/s
"10"	$s = 10$ mm	$v = 10$ mm/s
"50"	$s = 50$ mm	$v = 25$ mm/s
"100"	$s = 100$ mm	$v = 50$ mm/s

The "100" key is also programmable. The distance can be selected from 1 mm to 405 mm, the velocity from 1 mm/s to 100 mm/s (see 5.).

The movement of the sled is uniform: $v = \text{constant}$.

Precision of moved distance: ± 0.1 %

Connetions:

- 1x Output voltage (5),
 $V_{OUT} = 0$ V bis $\pm 4,05$ V
- 1x CMA interface (8)
Sensor cable 1021514 required
- 1x Sub-D *Sliding Rail* (1)
- 1x Hollow bushing (4), supply voltage
- 2x Ground socket (7)

Supply voltage:	12 V AC
Dimensions:	110x170x30 mm3
Weight:	1 kg

5. Operation

- Connect the sliding rail and the control unit. After connect the power supply to the control unit. The current position of the sled is the so called "home" position (voltage U_{out} between (5) and the reference point (7) is 0 V).
- By pressing the "home" key, the sled moves back to the "home" position from any position.
- A new "home" position can be set at any desired sled position by pressing the two function keys (6) simultaneously.

- The "home" position is changed when the sled collides with components or hits the end of the carriageway. The "home" position should be reset afterwards.
- The sled moves away from the motor by pressing the "step size" buttons once. The sled is moved by the according value.
- Movements towards the motor are initiated by pressing the "back" key (6) and a step size key (3) at the same time.
- The display is updated each time the sled has finished its movement. The voltage output corresponds always to the actual position of the sled.
- A 100 mm distance corresponds to a voltage change (5) of 1V.
- Alternatively the "100" key can be programmed with freely selectable values for the distance s and the speed v .

Programming example for $s = 152$ mm and $v = 65$ mm/s:

Press the two function keys (6) simultaneously for 3 s. The display shows: "CUSTOMIZE 100" and then " $s = 0$ mm". Press the following *step size* keys: 1x "100", 1x "50" and 2x "1". The display shows: " $s = 152$ mm". Confirm this value with the "home" key. Display: " $s = 152$ mm" " $v = 0$ mm/s".

Next press 1x "50", 1x "10" and 1x "5". Display: " $v = 65$ mm/s". Confirm this value again with the "home" key. The programming is completed.

The distance s can be set between 1 mm and 405 mm. The speed v can be set between 1 mm/s and 100 mm/s. Values $s > 0$ and $v > 0$ must be selected, otherwise "increase" is shown in the display.

After a device restart, the "100" key is again assigned the default values $s = 100$ mm and $v = 50$ mm/s.

Adjustment of the clutch force (14):

The clutch force of the sled (13) can be adjusted to protect sensitive components. At maximum force coupling and a "hard" collision, audible magnetic cogging torques occur at the motor (chatter). If possible, only set the required force coupling: clockwise rotation of (14) for higher force, counterclockwise rotation for lower force.

6. Disposal

The packaging should be disposed of at local recycling points. Should you need to dispose of the equipment itself, never throw it away in normal domestic waste. Local regulations for the disposal of electrical equipment will apply.

